

DOUBLE BLAZE™ LED TAPE LIGHT

INSTALLATION GUIDE

WARNING!

DO NOT CONNECT DIRECTLY TO HIGH VOLTAGE POWER!
Read all warnings and installation instructions thoroughly.

HANDLE LED TAPE LIGHT WITH CARE!

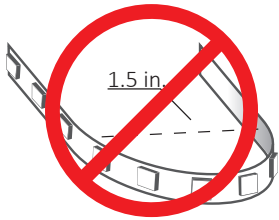

DO NOT BEND LED STRIP LIGHT TO A DIAMETER LESS THAN 1.5 INCHES.

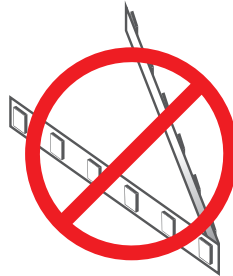

DO NOT FOLD, CREASE, OR TWIST LED STRIP LIGHT.

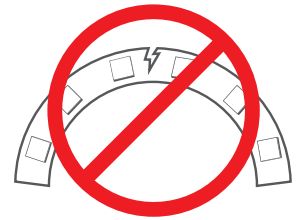

DO NOT BEND LED STRIP LIGHT ON A HORIZONTAL PLANE.



DO NOT PUT EXCESSIVE PRESSURE ON SURFACE OF TAPE LIGHT (GLASS/ACRYLIC PANES, ETC.)

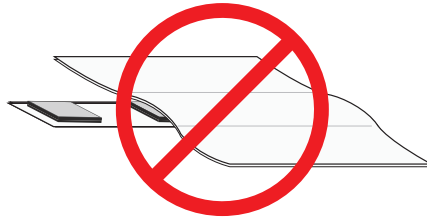

DO NOT COVER STRIP LIGHT WITH ANY MATERIALS.

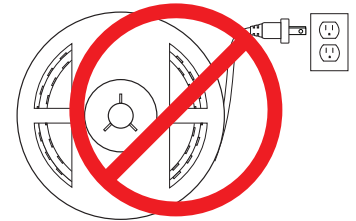

DO NOT POWER STRIP LIGHT WHILE ATTACHED TO SPOOL OR TIGHTLY COILED.

SAFETY & WARNINGS

- Install in accordance with the national and local electrical code regulations.
- This product is intended to be installed and serviced by a qualified, licensed electrician.
- Only install with a Class 2 DC Constant Voltage LED driver. This product has not been evaluated for use when connected to an LED driver that does not comply with Class 2 voltage and energy limited supplies.
- Only use copper wiring. Use wires rated for at least 176°F (80°C) and certified for use with external connection of electrical equipment.
- Inadequate wire installation could overheat wires, and cause a fire. Install applicable wire between driver, fixture, and any controls in between. When choosing wire, factor in voltage drop, amperage rating, and type (in-wall rated, wet location rated, etc.).
- Tape light, attached wire leads, and additional extension cables, connectors, etc., *are not* rated for in-wall installation unless otherwise noted. Tape light and attached wire leads are field-cuttable.
- Each Maximum Run requires a dedicated power feed from the driver.
- Do not install in environment where LED chips are exposed to direct sunlight as damage to the phosphor will occur.
- Do not install in environment where excessive heat may exist (ex. close proximity to fireplace, etc.) See Ambient Temperature note below.
- Only wet location tape light models are rated for outdoor / wet locations. See package label for environment ratings.
- Do not submerge wet location tape in liquids. Do not install wet location tape light in areas where water will puddle.

QUICK SPECS

Input Voltage	12VDC or 24VDC
Power Consumption	5.75w/ft
Maximum Run	9.5 or 16.4 feet
Environment	Indoor

Included Models ¹	DI-12V-DB** & DI-12V-DB**
Ambient Temperature ²	-4° ~ 122°F (-20° ~ 50°C)

Note ¹ ** Indicates luminaire CCT, length.

Note ² Do not install product in an environment outside the listed ambient temperature.

INSTALLATION

Prior to installation, verify all components (LED Tape, Driver, Control, & Accessories) are compatible. Configure and pre-test your LED system prior to installation to ensure all components are operating correctly.

1 TURN POWER OFF AT CIRCUIT BREAKER.

 **SHOCK HAZARD! May result in serious injury or death.**
Turn power OFF at circuit breaker prior to installation.

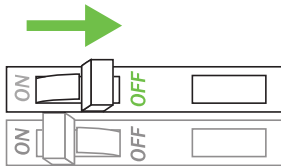

2 DETERMINE LOCATION TO INSTALL COMPONENTS.

Refer to **SYSTEM DIAGRAMS**.

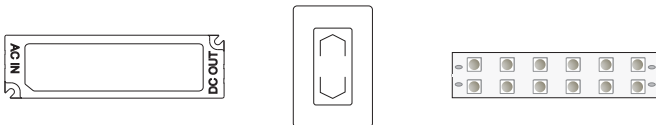

1) Class 2 Driver 2) Control 3) Tape Light

WIRE GAUGE & VOLTAGE DROP
Ensure applicable wire is installed between driver, fixture, and any controls in between. When choosing wire, factor in voltage drop, amperage rating, and type (in-wall rated, wet location rated, etc.)

3 CUT TAPE LIGHT TO DESIRED LENGTH.

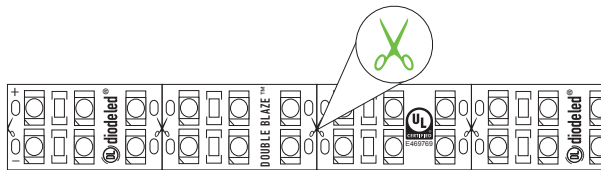

Cut at line indicated with scissors icon.
**NOTE: Cutting anywhere else will damage the Tape Light.*

4 ATTACH DOUBLE BLAZE CONNECTORS

Never cut tape attached to a live circuit. Do not exceed Class 2 Limit when loading Double Blaze Connectors.

 **CONNECTOR LOAD LIMIT**
12VDC: 60W, 5A 24VDC: 100W, 4.17A

4.1 PULL BLACK TAB.

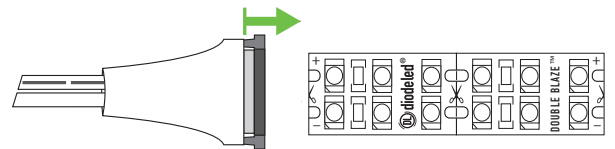

Gently pull out the black tab 1-2mm. Note the +/- polarity markings of the tape light.

4.2 FIRMLY INSERT TAPE LIGHT INTO CONNECTOR TRAY WITH 3M™ ADHESIVE BACKING STILL INTACT TO TAPE.

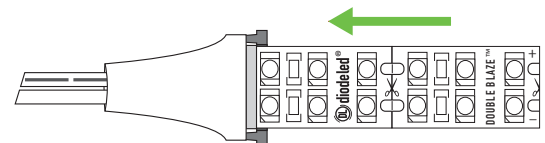

Ensure contact/solder points of tape light are directly underneath white/gray tab of connector tray.

4.3 FIRMLY CLOSE CONNECTOR TRAY.

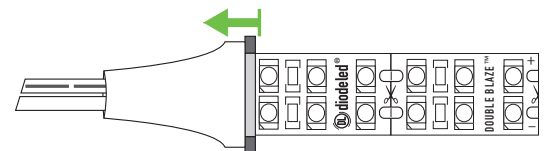

5 TEST CONNECTION.



Prior to mounting, attach to Class 2 LED Driver, turn on power and test connection to ensure system is operating properly. Turn off power again before mounting.

INSTALLATION CONT.

6 MOUNT TAPE LIGHT.

Clean surface before mounting.

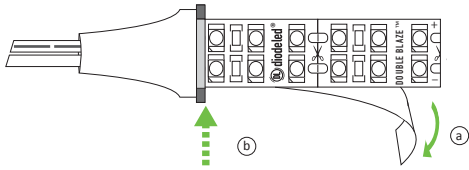

a Peel off 3M™ Adhesive Backing. **Ensure ambient temp is minimum 50 °F (10 °C) or tape will not adhere properly.**

b Tear off backing along connector edge.

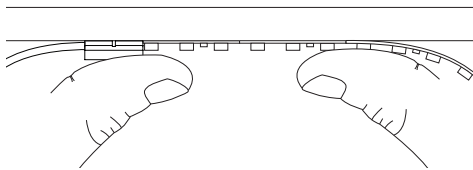

c Adhere to a smooth, dry surface, working one end to the other.

7 ATTACH DRIVER AND LIGHTING CONTROL.

ONLY USE COPPER WIRING. See **SYSTEM DIAGRAMS** on page 4. Verify a compatible driver and control are installed.

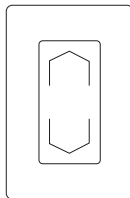
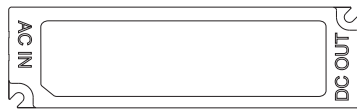

REVIEW FULL SYSTEM and ensure all polarities are correct and connections are secure.

8 TURN POWER ON AT CIRCUIT BREAKER.

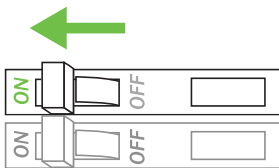

SYSTEM WORKING IMPROPERLY?

Turn power OFF at circuit breaker and verify all connections. Review **SYSTEM DIAGRAMS** and **TROUBLESHOOTING** or call Diode LED Technical Support at 877.817.6028.

TROUBLESHOOTING

Symptom	Common Cause
Tape Light does not illuminate	<ul style="list-style-type: none"> Circuit breaker is OFF or tripped. Incorrect wiring. Polarity of Low Voltage V+ and V- are reversed. Check connection at every connection point to ensure polarity is not reversed. Incorrect voltage pairing of LED driver and fixture. Ensure tape light models are not paired with a driver of a different voltage.
Tape Light Overheats	<ul style="list-style-type: none"> Incorrect ambient temperature. Ensure tape light is installed in environment -4° ~ 122°F (-20° ~ 50°C).
Fixture flickers randomly, may shut off	<ul style="list-style-type: none"> Connection is not secure. Check connection at DOUBLE BLAZE™ connector, and ensure that it is fastened securely.
Shift in brightness and/or color	<ul style="list-style-type: none"> Review Tape Light maximum series run limit. Exceeding will cause voltage drop, decreasing brightness and/or color shift. Review Voltage Drop Charts on pg. 6. Incorrect wire gauge may cause voltage drop and noticeable shift in brightness and/or color.
Tape Light turns on/off repeatedly	<ul style="list-style-type: none"> Driver is overloaded or overheated. An overloaded/overheated driver will trip the internal auto-reset (of driver) repeatedly, turning the system on/off.
DOUBLE BLAZE™ Connectors	<ul style="list-style-type: none"> Tape Light is polarity sensitive. Ensure V+ of power is attached to V+ of tape light. Ensure V- of power is attached to V- of tape light.

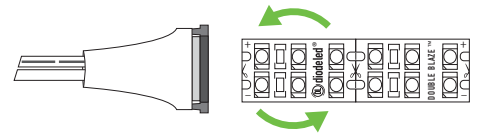

SYSTEM DIAGRAMS

The following diagrams are provided as example system designs. For information regarding larger systems or systems not pictured below, please see our web page or contact technical support. Always review each component installation guide for detailed and up-to-date wiring instructions. Install in accordance with NEC and local regulations.

SWITCHEX® DIMMER+DRIVER SYSTEM

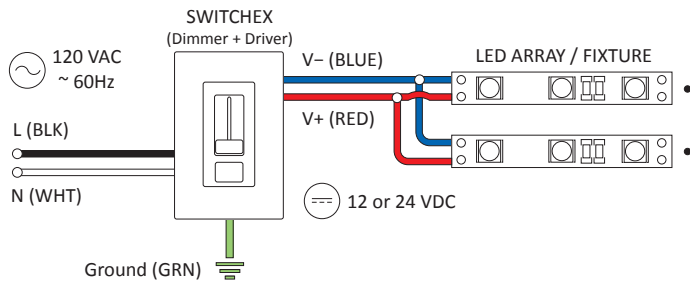

PLUG-IN ADAPTER SYSTEM

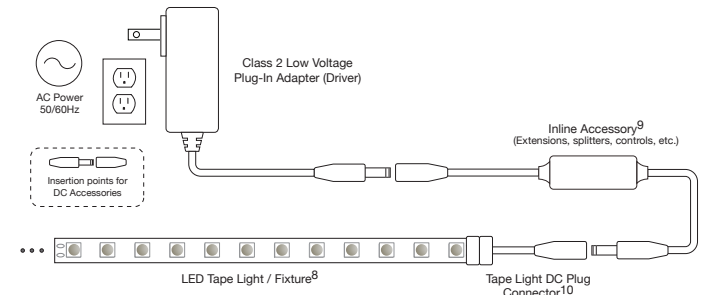

OMNIDRIVE® ELECTRONIC DIMMABLE DRIVER SYSTEM

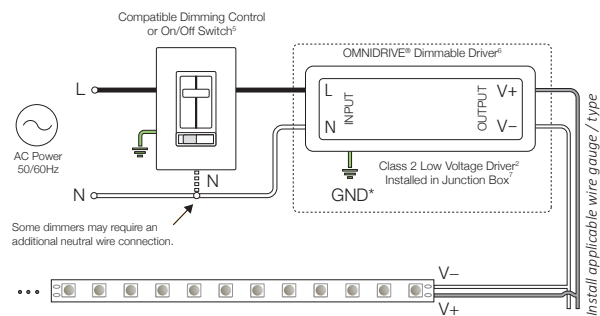

TRADITIONAL ON/OFF SYSTEM

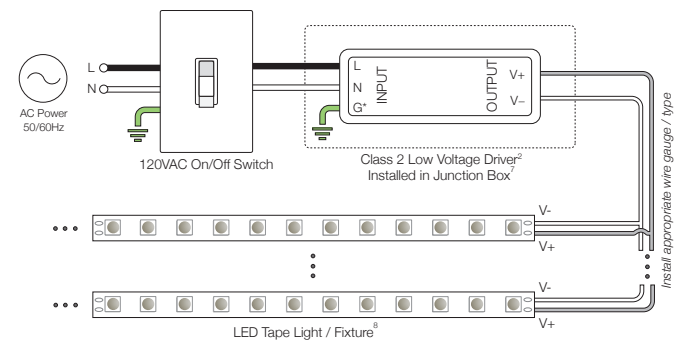

REIGN® 12-24V DIMMER SYSTEM

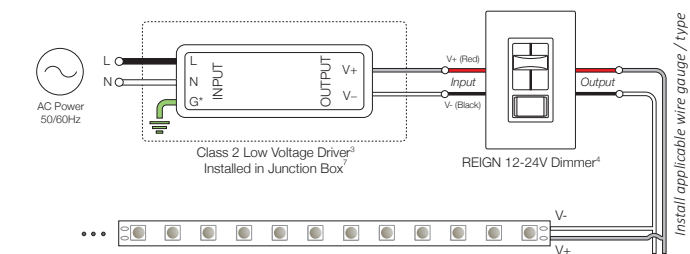

MAGNETIC DIMMABLE DRIVER SYSTEM

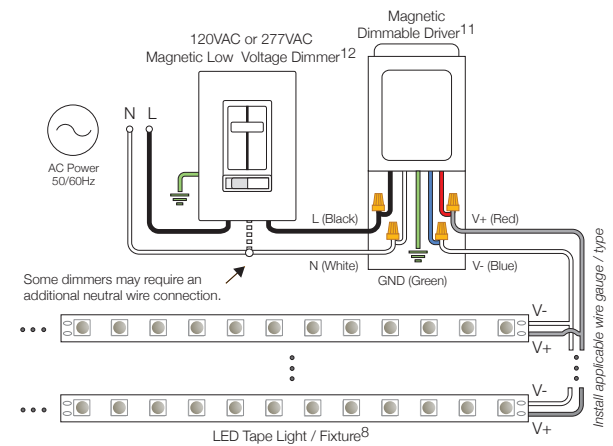

See page 5 for footnote references.

SYSTEM DIAGRAM FOOTNOTES

1. Driver may not require a fault ground connection. Refer to driver specifications for additional information.
2. Install a compatible Class 2 constant voltage driver. Refer to each driver specification sheet for full power ratings & load deratings.
3. Install a Class 2 constant voltage driver compatible with a low voltage PWM controller/dimmer switch. Refer to each driver specification sheet for full power ratings & load deratings.
4. Determine the number of low voltage outputs of the driver when installing multiple PWM controllers/dimmer switches. No more than one PWM controller/dimmer switch can be attached to a single output of the driver.
5. Install a compatible dimming control or switch. See the 'Electronic Dimmable Driver / Dimmer Compatibility List' for compatible dimming controls. See the dimming control manufacturer installation guide for complete wiring instructions.
6. Ensure to load the driver at least 60% of the labeled load for proper dimming performance (required for dimmable installations only).
7. Refer to driver or controller specifications for a compatible junction box.
8. See fixture specifications for maximum series run limits.
9. See in-line accessories specifications for maximum amperage ratings.
10. See fixture accessories for a compatible adapter connector.
11. Dimmable drivers may require a compatible magnetic low voltage dimmer switch to supply the driver and fixture with appropriate input voltage. Do not test or install directly connected to an AC power source or to an On/Off switch. Refer to each driver specification sheet for full power ratings & load deratings. See spec sheet for potential updated information. See dimmer switch manufacturer specifications for minimum load recommendations.
12. Install a compatible magnetic low voltage dimmer switch. See the MFG installation guide for complete wiring instructions.

VOLTAGE DROP CHARTS

For best performance and lumen output, ensure proper wire gauge is installed to compensate for voltage drop of low voltage circuits.

Example: 24V Voltage Drop & Wire Length Distance Chart

Wire Gauge	10 W .42 A	20 W .83 A	30 W 1.3 A	40 W 1.7 A	50 W 2.1 A	60 W 2.5 A
18 AWG	134 ft.	68 ft.	45 ft.	33 ft.	27 ft.	22 ft.
16 AWG	215 ft.	109 ft.	72 ft.	54 ft.	43 ft.	36 ft.
14 AWG	345 ft.	174 ft.	115 ft.	86 ft.	69 ft.	57 ft.
12 AWG	539 ft.	272 ft.	181 ft.	135 ft.	108 ft.	90 ft.
10 AWG	784 ft.	397 ft.	263 ft.	197 ft.	158 ft.	131 ft.

① Determine load size. Let's assume load is 55 W. Round up to nearest load.

② Determine distance from driver to load. Let's assume the distance is 90 ft.

③ It is recommended to install 12 AWG to eliminate excess voltage drop.

24V Voltage Drop & Wire Length Distance Chart

Wire Gauge	10 W .42 A	20 W .83 A	30 W 1.3 A	40 W 1.7 A	50 W 2.1 A	60 W 2.5 A	70 W 2.9 A	80 W 3.3 A	100 W 4.2 A
18 AWG	134 ft.	68 ft.	45 ft.	33 ft.	27 ft.	22 ft.	19 ft.	17 ft.	14 ft.
16 AWG	215 ft.	109 ft.	72 ft.	54 ft.	43 ft.	36 ft.	31 ft.	27 ft.	22 ft.
14 AWG	345 ft.	174 ft.	115 ft.	86 ft.	69 ft.	57 ft.	49 ft.	43 ft.	36 ft.
12 AWG	539 ft.	272 ft.	181 ft.	135 ft.	108 ft.	90 ft.	77 ft.	68 ft.	56 ft.
10 AWG	784 ft.	397 ft.	263 ft.	197 ft.	158 ft.	131 ft.	112 ft.	98 ft.	82 ft.

ADDITIONAL RESOURCES

Visit the on-line product page at www.DiodeLED.com for individual LED Tape Light product specifications & warranty information.



Toll Free: 877.817.6028 | Fax: 415.592.1596 | www.DiodeLED.com | info@DiodeLED.com
 © 2017 Elemental LED, Inc. All rights reserved. Specifications are subject to change without notice.